

2013 New Hampshire State Mathematics Contest

Sponsored by USNH and New Hampshire Teachers of Mathematics

Team Essay (category 1)

INSTRUCTIONS: You should provide a complete solution to the following problem. This problem is worth 18 points, of which 3 points will be awarded for the style of the solution. The readers are interested in the coherence of the explanation and the organization of the solution. Feel free to use words, diagrams, etc.

DIAGRAM 1

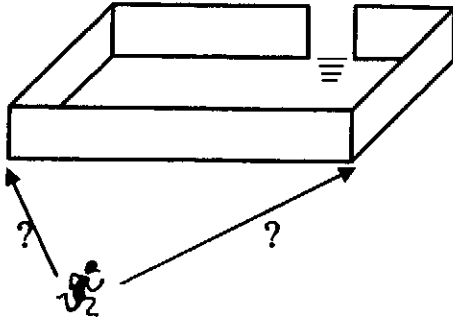
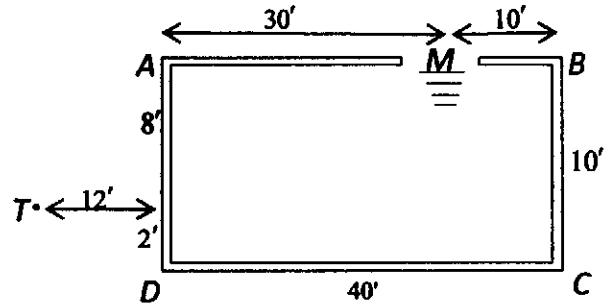

DIAGRAM 2



I am late for a flight from Washington DC to NH. I am running to the Metro at Union Station in Washington to catch a subway to the airport. The down escalator to the Metro is surrounded by a four foot high brick wall, but is otherwise open (see diagram 1). Since I am in a hurry, I must find the shortest path to the entrance of the Metro around the brick wall. Hmmm...should I go around to the left or to the right?? An overhead drawing of the situation is shown in diagram 2.

1. Find the length of the shortest path from point T to the down escalator at M .

DIAGRAM 3

Use DIAGRAM 3 to answer questions 2 and 3.

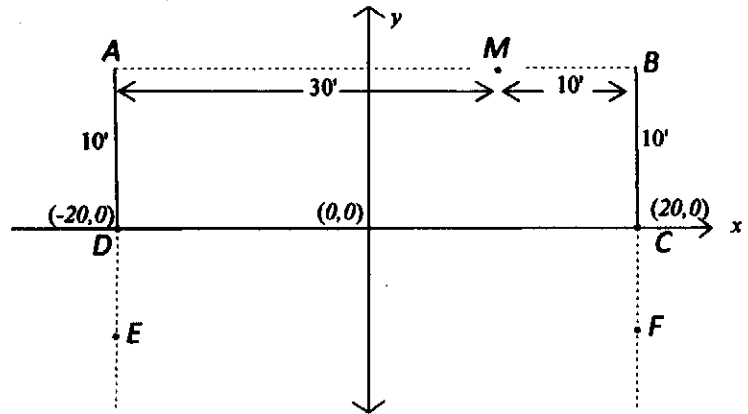

2. Find the point along ray \overline{DE} where the distance to M around to the left is the same as the distance to M around to the right.

3. Find an equation of the set of points (x,y) in the open region $EDCF$ such that the distance to M around to the left is the same as the distance to M around to the right.

4. Sketch and describe the collection of points in the open region $EDCF$ where the distance to M around to the left is less than the distance to M around to the right.

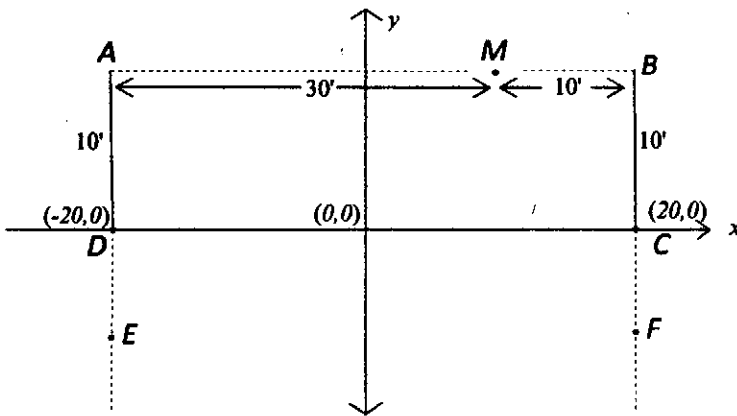

2013 New Hampshire State Mathematics Contest

Sponsored by USNH and New Hampshire Teachers of Mathematics

Team (category 1)
(35 minutes)

1. Starting at point A , draw three connected line segments, which are entirely within or on the grid, that separate the whole grid into five regions of equal area.

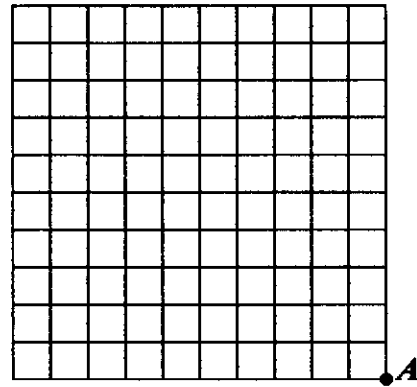

Answer _____

2. In the figure, all shaded triangles are equilateral. The length of a side of the regular pentagon is 1 inch. Find the radius of the circle.

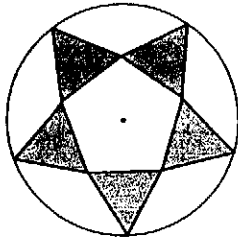

Answer _____ in

3. Find 20 consecutive natural numbers, none of which is a prime number.

Answer _____

2013 New Hampshire State Mathematics Contest

Sponsored by USNH and New Hampshire Teachers of Mathematics

Recreational Math (category 2)
(12 minutes)

1. Which patterns below form a closed cube when folded along the dotted lines? List all possibilities.

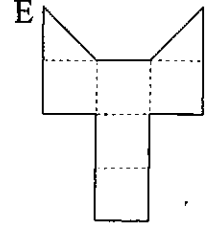
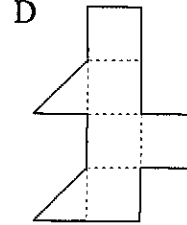
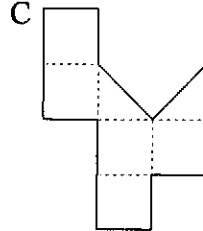
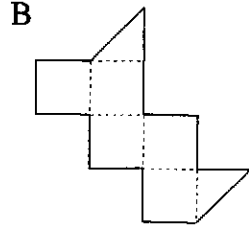
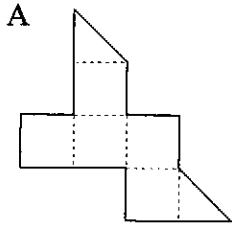

Answer _____

2. The 3-D shape consists of six cubes in three shades. Twelve 2-D views (A-L) are shown. Which are correct? List all possibilities.

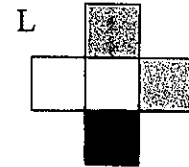
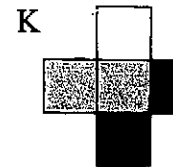
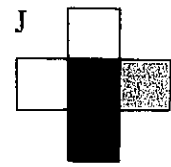
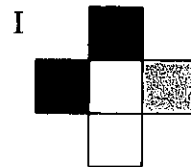
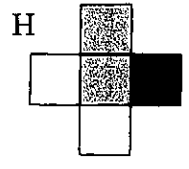
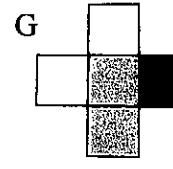
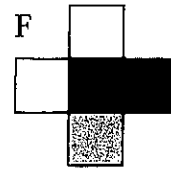
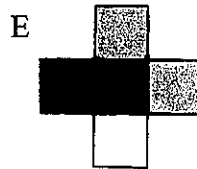
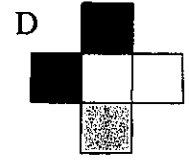
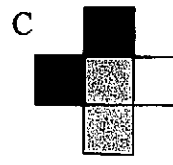
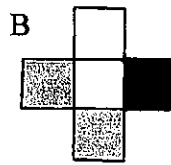
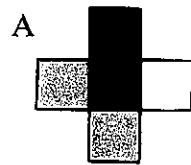
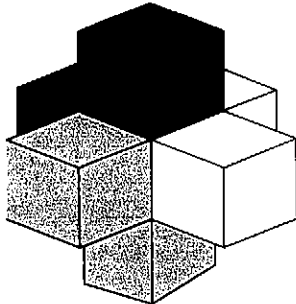

Answer _____

3. An equilateral triangle is divided into two shapes: a small triangle and a trapezoid. Each shape has an area of 1. If the ratio of the height of the small triangle to the height of the trapezoid is $1 : x$, find the exact value of x .

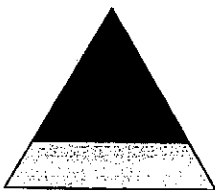

Answer _____

2013 New Hampshire State Mathematics Contest

Sponsored by USNH and New Hampshire Teachers of Mathematics

Algebra I (category 3)

(12 minutes)

1. How many integers between 10,001 and 20,000 are perfect squares?

Answer _____

2. What is the value of x if $6^{x+1} - 6^x = 1080$?

Answer _____

3. Find the product pq such that each solution of the equation $x^2 + px + q = 0$ is one less than a solution of the equation $x^2 - 5x - 6 = 0$.

Answer _____

2013 New Hampshire State Mathematics Contest

Sponsored by USNH and New Hampshire Teachers of Mathematics

Geometry (category 4)

(12 minutes)

1. $DEBK$ is a rectangle and the length of \overline{BE} is 1 cm. What is the length of \overline{AG} ?

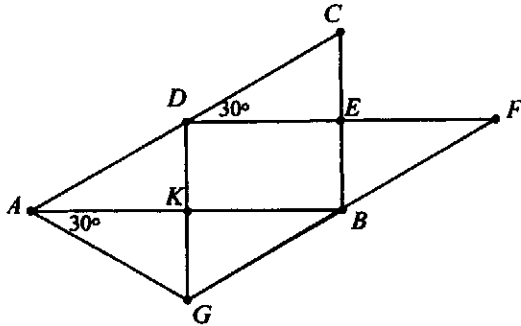

Answer _____ cm

2. The length of a band wrapped tightly around three coplanar circular disks is 12 centimeters. If the disks have equal radii and are tangent to each other as shown, what is the radius of each disk in centimeters?

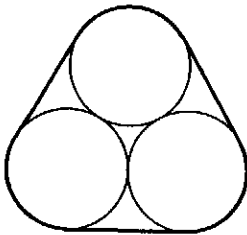

Answer _____

3. In $\triangle ABC$, $BC = 12$, $AC = 10$, D is the midpoint of \overline{BC} and E lies on \overline{AC} so that $m\angle ADE = m\angle CDE$ and \overline{DE} is parallel to \overline{AB} . What is the length of \overline{ED} ?

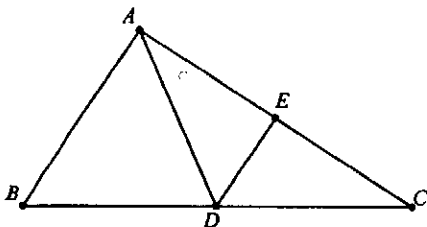

Answer _____ units

2013 New Hampshire State Mathematics Contest

Sponsored by USNH and New Hampshire Teachers of Mathematics

Algebra II (category 5)

(12 minutes)

1. Suppose that $\frac{x}{y} = \frac{4}{7}$ and $\frac{y}{z} = \frac{14}{3}$. What is the value of $\frac{x+y}{z}$?

Answer _____

2. Let $P(x) = kx^3 + 2k^2x^2 + k^3$. Find the sum of all real numbers k for which $x - 2$ is a factor of $P(x)$.

Answer _____

3. Find the limiting value of the following continued fraction.

$$1 + \frac{1}{1 + \frac{1}{1 + \frac{1}{1 + \frac{1}{1 + \dots}}}}$$

Answer _____

2013 New Hampshire State Mathematics Contest

Sponsored by USNH and New Hampshire Teachers of Mathematics

Advanced Math (category 6)

(12 minutes)

1. Suppose the function f is defined as: $f(n) =$ the n^{th} digit to the right of the decimal point in the decimal expansion of $\frac{1}{7}$. What is the value of $f(2013)$?

Answer _____

2. Find an equation for the circle with radius 5 which is tangent to both branches of the graph of $y = |x|$.

Answer _____

3. Find all values of x for which $(\sqrt{2})^{\tan x} = \left(\frac{1}{2}\right)^{\sin x}$. Give exact values.

Answer _____